

## 300mW, NPN Small Signal Transistor

### FEATURES

- Low power loss, high efficiency
- Ideal for automated placement
- High surge current capability
- Moisture sensitivity level: level 1, per J-STD-020
- RoHS Compliant
- Halogen-free according to IEC 61249-2-21

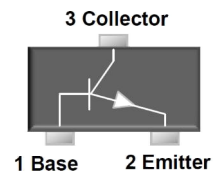
### APPLICATIONS

- Switching mode power supply (SMPS)
- Adapters
- Lighting application
- On-board DC/DC converter

### MECHANICAL DATA

- Case: SOT-23
- Molding compound: UL flammability classification rating 94V-0
- Matte tin plated leads, solderable per J-STD-002
- Meet JESD 201 class 1A whisker test
- Polarity: Indicated by cathode band
- Weight: 8 mg (approximately)

KEY PARAMETERS		
PARAMETER	VALUE	UNIT
$V_{CBO}$	75	V
$V_{CEO}$	40	V
$V_{EBO}$	6	V
$I_C$	600	mA
$h_{FE}$	300	
Package	SOT-23	
Configuration	Single die	



ABSOLUTE MAXIMUM RATINGS ( $T_A = 25^\circ\text{C}$ unless otherwise noted)			
PARAMETER	SYMBOL	MMBT2222A	UNIT
Marking code on the device		1P	
Collector-base voltage, emitter open	$V_{CBO}$	75	V
Collector-emitter voltage, base open	$V_{CEO}$	40	V
Emitter-base voltage, collector open	$V_{EBO}$	6	V
Collector current, dc	$I_C$	600	mA
Total dc power input to all terminals	$P_T$	300	mW
Junction temperature	$T_J$	-55 to +150	$^\circ\text{C}$
Storage temperature	$T_{STG}$	-55 to +150	$^\circ\text{C}$

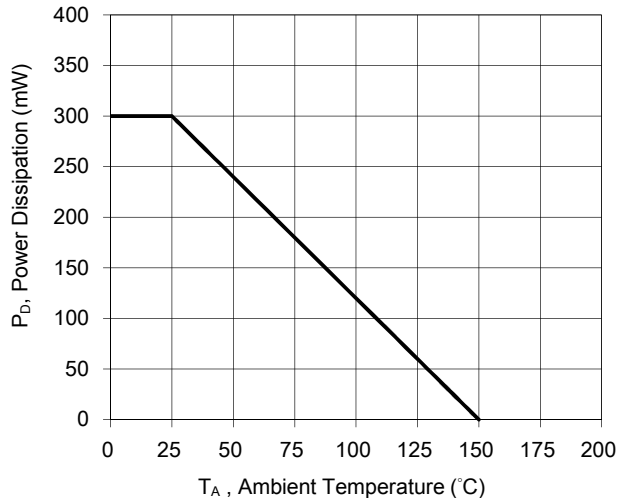
<b>ELECTRICAL SPECIFICATIONS</b> ( $T_A = 25^\circ\text{C}$ unless otherwise noted)						
PARAMETER	CONDITIONS	SYMBOL	MIN	TYP	MAX	UNIT
Collector-base breakdown voltage, emitter open	$I_C = 10\ \mu\text{A}, I_E = 0$	$V_{(BR)CBO}$	75	-	-	V
Collector-emitter breakdown voltage, base open	$I_C = 10\ \text{mA}, I_B = 0$	$V_{(BR)CEO}$	40	-	-	V
Emitter-base breakdown voltage, collector open	$I_E = 10\ \mu\text{A}, I_C = 0$	$V_{(BR)EBO}$	6	-	-	V
Collector cutoff current, emitter open	$V_{CB} = 60\ \text{V}, I_E = 0$	$I_{CBO}$	-	-	0.01	$\mu\text{A}$
Emitter cutoff current, collector open	$V_{EB} = 3\ \text{V}, I_C = 0$	$I_{EBO}$	-	-	0.1	$\mu\text{A}$
DC Current Gain	$V_{CE} = 10\ \text{V}, I_C = 500\ \text{mA}$	$h_{FE}$	40	-	-	
	$V_{CE} = 10\ \text{V}, I_C = 150\ \text{mA}$		100	-	300	
	$V_{CE} = 10\ \text{V}, I_C = 10\ \text{mA}$		75	-	-	
	$V_{CE} = 10\ \text{V}, I_C = 1\ \text{mA}$		50	-	-	
	$V_{CE} = 10\ \text{V}, I_C = 0.1\ \text{mA}$		35	-	-	
Collector-emitter saturation voltage	$I_C = 500\ \text{mA}, I_B = 50\ \text{mA}$	$V_{CE(sat)}$	-	-	1	V
Base-emitter saturation voltage	$I_C = 500\ \text{mA}, I_B = 50\ \text{mA}$	$V_{BE(sat)}$	-	-	2	V
Transition frequency	$V_{CE} = 20\ \text{V}, I_C = 20\ \text{mA}, f = 100\ \text{MHz}$	$f_T$	300	-	-	MHz
Output Capacitance	1 MHz, $V_{CB} = 10\ \text{V}, I_E = 0$	$C_{OBO}$	8			pF
Input Capacitance	1 MHz, $V_{EB} = 0.5\ \text{V}, I_C = 0$	$C_{IBO}$	25			pF
Delay Time	$V_{CC} = 30\ \text{V}, V_{BE(off)} = -0.5\ \text{V}, I_C = 150\ \text{mA}$	$t_d$	-	-	10	ns
Rise Time	$I_{B1} = 15\ \text{mA}$	$t_r$	-	-	25	ns
Storage Time	$V_{CC} = 30\ \text{V}, I_{B1} = -I_{B2} = 15\ \text{mA}, I_C = 150\ \text{mA}$	$t_s$	-	-	225	ns
Fall Time	$V_{CC} = 30\ \text{V}, I_{B1} = -I_{B2} = 15\ \text{mA}, I_C = 150\ \text{mA}$	$t_f$	-	-	60	ns

<b>ORDERING INFORMATION</b>		
ORDERING CODE	PACKAGE	PACKING
MMBT2222A RFG	SOT-23	3K / 7" Reel

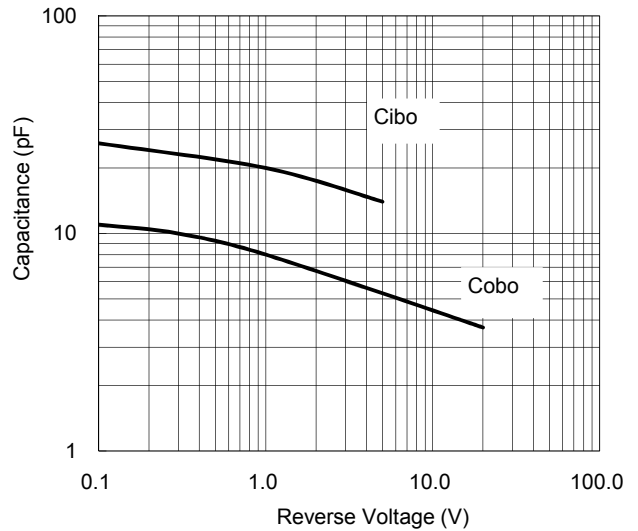
**CHARACTERISTICS CURVES**

( $T_A = 25^\circ\text{C}$  unless otherwise noted)

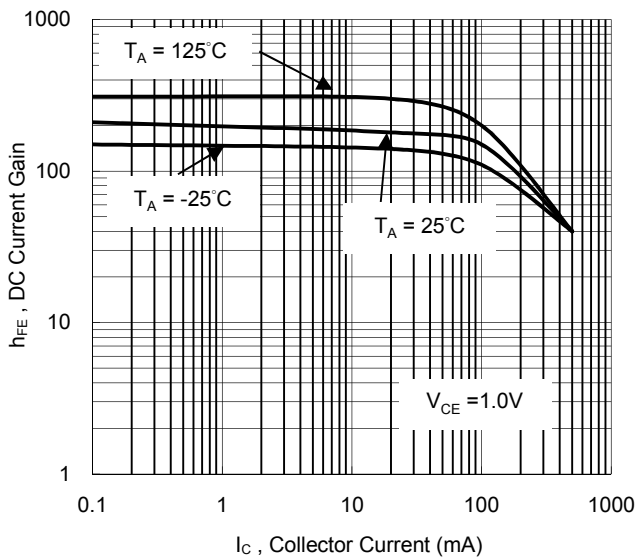
**Fig. 1 Max Power Dissipation VS. Ambient Temperature**



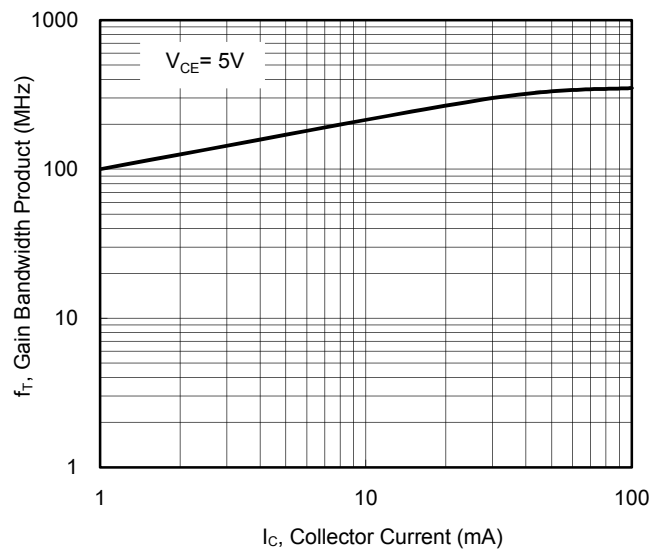
**Fig.2 Typical Capacitance**



**Fig.3 Typical DC Current Gain VS. Collector Current**



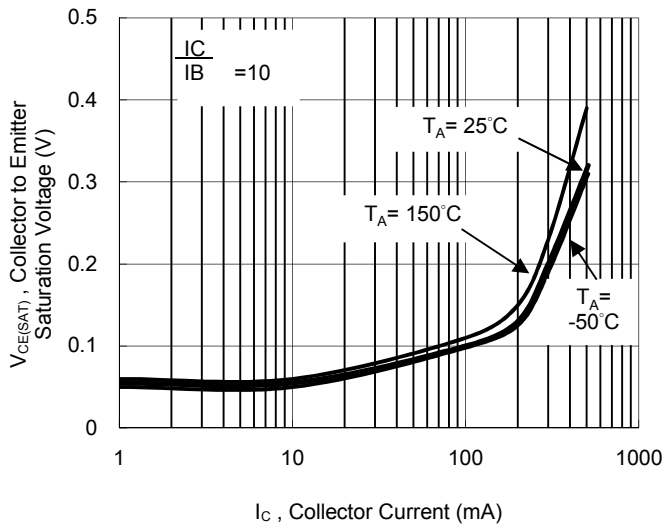
**Fig.4 Gain Bandwidth Product VS. Collector Current**



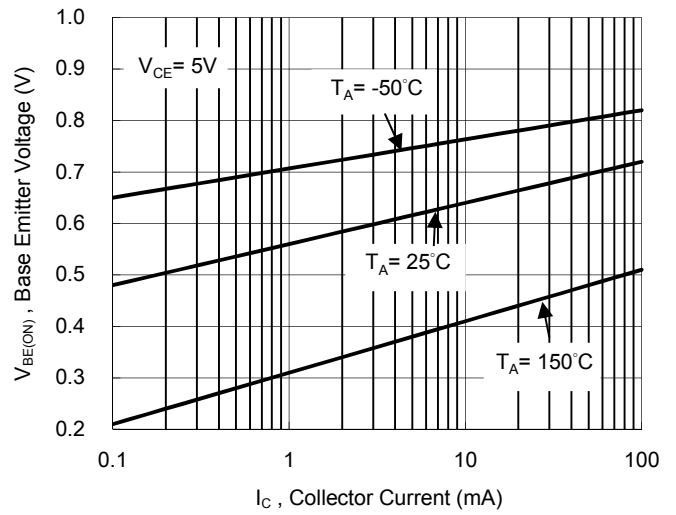
**CHARACTERISTICS CURVES**

( $T_A = 25^\circ\text{C}$  unless otherwise noted)

**Fig.5 Collector Emitter Saturation Voltage VS. Collector Current**

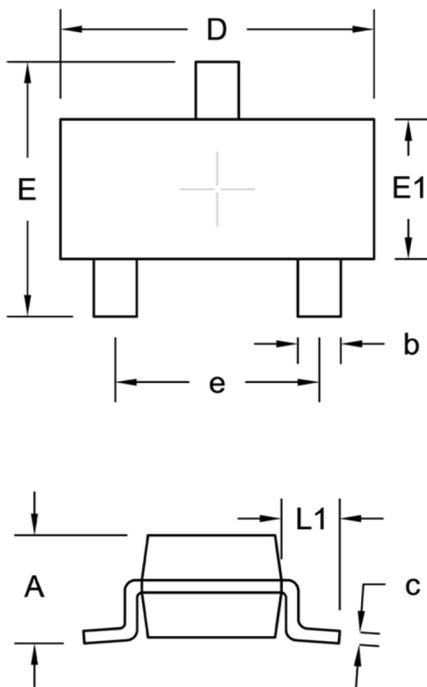


**Fig.6 Base Emitter Voltage vs. Collector Current**



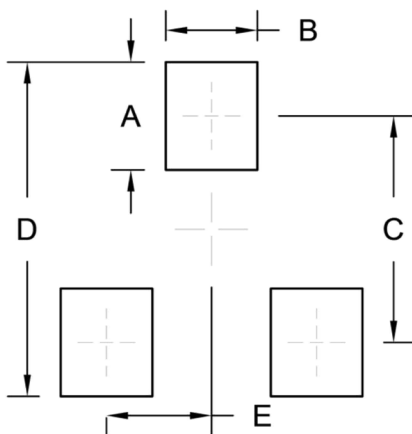
**PACKAGE OUTLINE DIMENSION**

**SOT-23**



DIM.	Unit (mm)		Unit (inch)	
	Min.	Max.	Min.	Max.
A	0.89	1.12	0.035	0.044
b	0.30	0.50	0.012	0.020
c	0.08	0.20	0.003	0.008
D	2.80	3.04	0.110	0.120
E	2.10	2.64	0.083	0.104
E1	1.20	1.40	0.047	0.055
e	1.90 BSC		0.075 BSC	
L1	0.54 REF.		0.021 REF.	

**SUGGESTED PAD LAYOUT**



Symbol	Unit (mm)	Unit (inch)
A	1.00	0.039
B	0.85	0.033
C	2.10	0.083
D	3.10	0.122
E	0.98	0.039